

WS

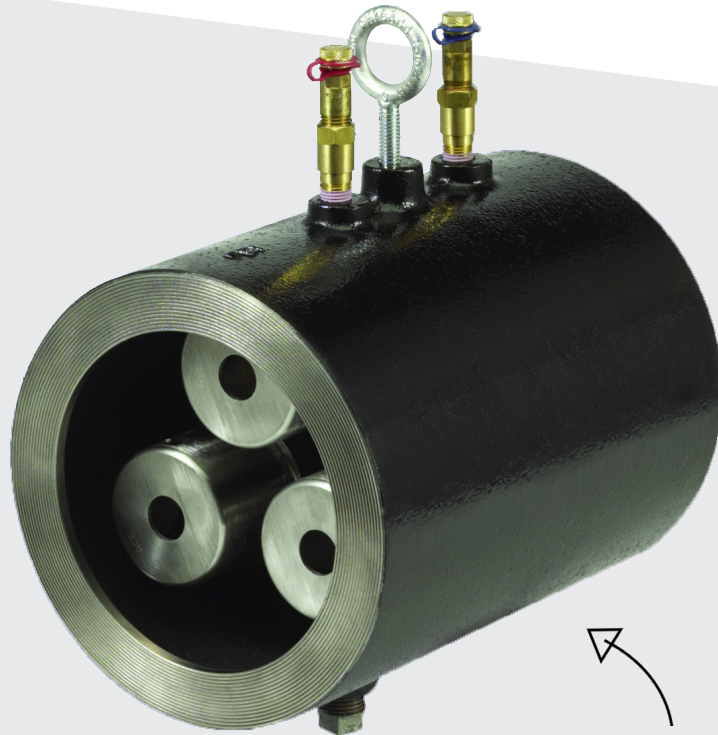

5" WS SHOWN

Automatic Balancing Valves
16" - 30" Automatic Flow Control

Engineering
GREAT Solutions

WS

Model WS is a wafer-style AutoFlow regulator factory set to automatically limit the specified flow to within ± 5 percent over 95 percent of the control range. The number of flow cartridges required is determined by the gpm requested. The valve body is compatible with ANSI Class 150 flanges. Extended Pressure / Temperature Ports and drain plug are standard. Options limited to quantity of three (2 at 12:00 and 1 at 6:00) and are shipped loose for field installation. Companion flanges and gaskets are not included.

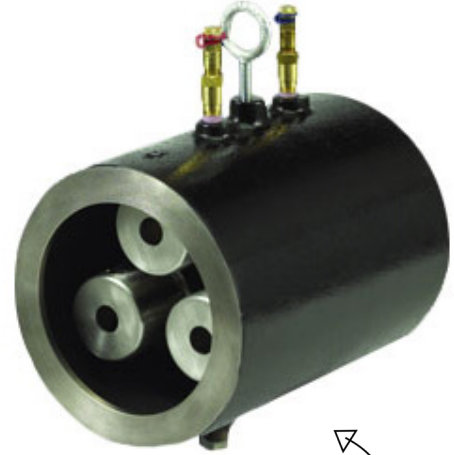

5" WS SHOWN

Key features

- > **Flow Regulator**
Reduced wasted pumping
- > **Changeable Cartridges**
- > **Tamper Resistant**

Technical description

Application:
Hydronic Balancing

Dimensions:
16" - 30"

Accuracy:
 ± 5 %

Functions:
Flow Regulator

Pressure class:
225 psig at 250° F (15 bar at 120° C)

Material:
Body: Fabricated steel
Flow cartridge: Stainless steel wear

Flow

Model	Maximum Flow gpm (lps)*									
	Control Range psi (kpa)									
	2-32 (1)		5-60 (2)		3-20 (3)		5-40 (4)		7-45 (5)	
	(14-220)		(35-414)		(21-138)		(34-276)		(48-310)	
WS1600(-)	*3105	(196)	3910	(246)	4600	(290)	5750	(362)	6900	(435)
WS1800(-)	*3780	(238)	4760	(300)	5600	(353)	7000	(441)	8400	(529)
WS2000(-)	*4320	(272)	5440	(343)	6400	(403)	8000	(504)	9600	(605)
WS2400(-)	*6075	(383)	7650	(482)	9000	(567)	11250	(709)	13500	(851)
WS3000(-)	*8910	(562)	11200	(708)	13200	(832)	16500	(1040)	19800	(1249)

Notes

The (-) in the model number must be replaced by: **1:** 2-32 (14-220); **2:** 5-60 (35-414); **3:** 3-20 (21-138); **4:** 5-40 (35-276) or **5:** 7-45 (48-310).

For pump head calculations, the following loss applies for each range: 4.6 ft. or 13.7 kPa (2-32); 11.6 ft. or 34.6 kPa (5-60); 6.9 ft. or 17.9 kPa (3-20); 11.6 ft. or 34.6 kPa (5-40) & 16.2 ft. or 48.4 kPa (7-45).

*gpm increments are 5 gpm for 2-32 & 5-60, 10 gpm for 3-20 & 5-40, 20 gpm for 7-45.

All weights and dimensions are subject to minor changes.

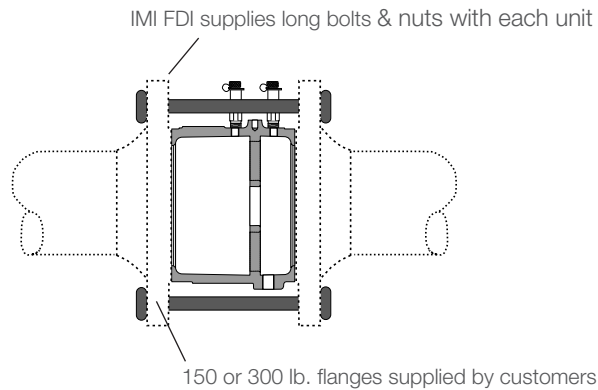

Articles

Dimensions

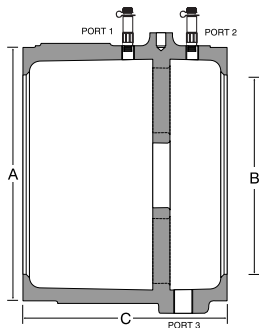

Model	Size		A		B		C		Max No. 3" Canisters	Weights	
	in.	(mm.)	in.	(mm.)	in.	(mm.)	in.	(mm.)		lb.	kg.
WS1600(-)	16.0	(400)	20.0	(508)	14.8	(375)	17.2	(437)	23	360	(163)
WS1800(-)	18.0	(450)	21.2	(539)	15.3	(390)	11	(279)	28	350	(159)
WS2000(-)	20.0	(500)	23.6	(599)	16.6	(420)	20.4	(518)	32	670	(304)
WS2400(-)	24.0	(600)	27.9	(709)	18.7	(475)	21.6	(549)	45	850	(386)
WS3000(-)	30.0	(760)	34.4	(873)	22.0	(560)	11	(280)	66	595	(270)

Model Order Designation

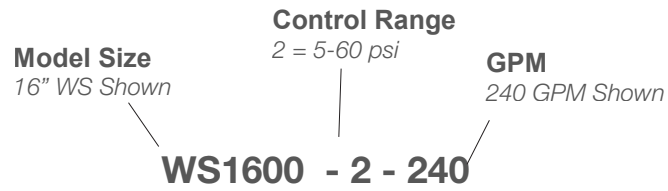

Options Available

MI Metal ID Tag

PI Plastic ID Tag



The products, texts, photographs, graphics and diagrams in this document may be subject to alteration by IMI Hydronic Engineering without prior notice or reasons being given. For the most up to date information about our products and specifications, please visit www.flowdesign.com.