

# AccuSetter

## A Manual Balancing Valve

*Engineering  
GREAT Solutions* ↘

- ✓ ACCURATE
- ✓ ADJUSTABLE
- ✓ EFFORTLESS BALANCING

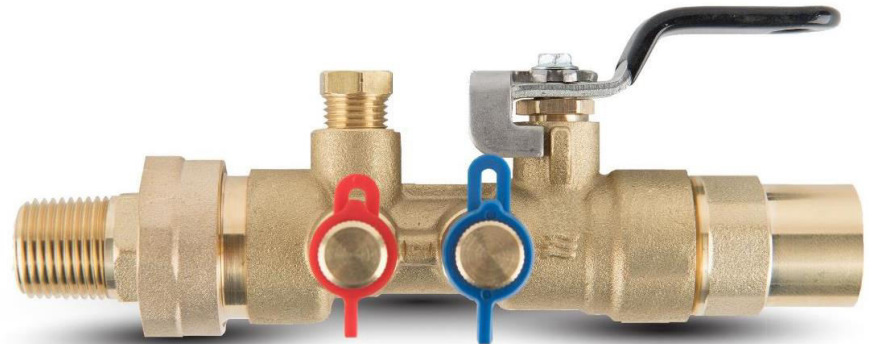

# Why Balance...

## And How?



# Obtaining the Flows

Engineering  
GREAT Solutions

IMI  
Hydronic  
Engineering

- ▶ Pumps provide a differential pressure
- ▶ Water flows establish themselves in function of the relative hydraulic resistances of branches with respect to each other

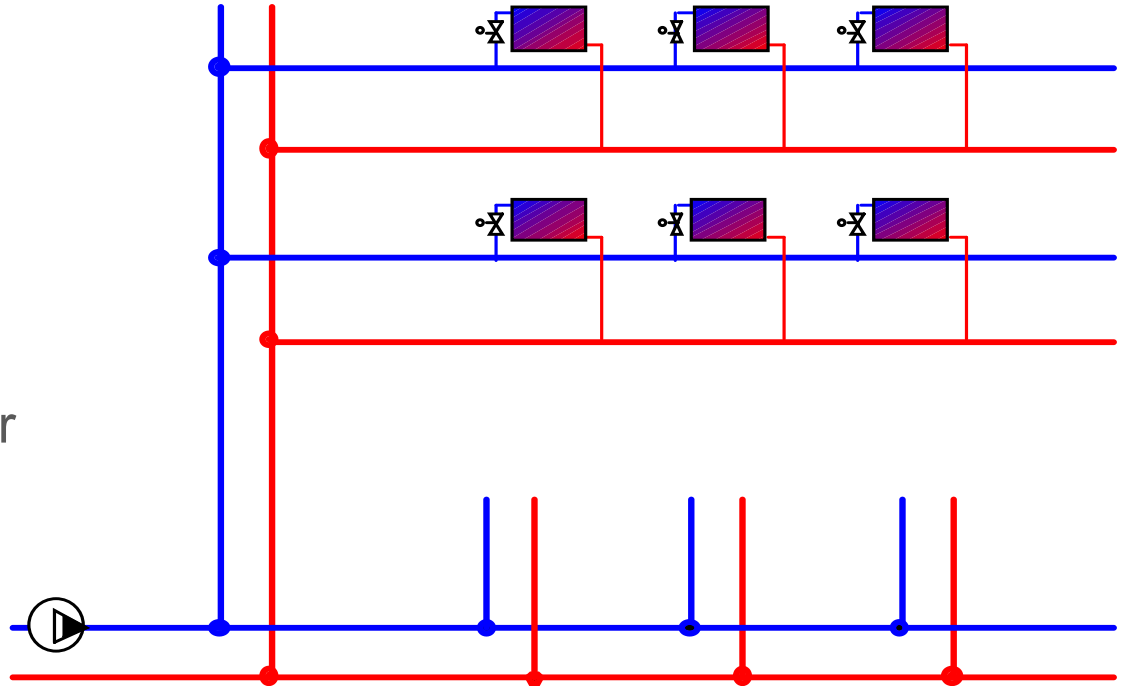

# Resolving Underflow Issue without a BV

Engineering  
GREAT Solutions

IMI  
Hydronic  
Engineering

- ▶ When  $q \sim \sqrt{\Delta p}$  and  $q$  need to increase 25%, the  $\Delta p$  has to increase  $1.25^2 = 56\%$
- ▶ This increases pump by 56% and increases pump energy cost by **95%!**

$$\text{Pump Cost} \sim C_0 \text{ (Base Cost)} + \frac{\text{Flow} \times \text{Pump Head}}{\text{Efficiency}}$$

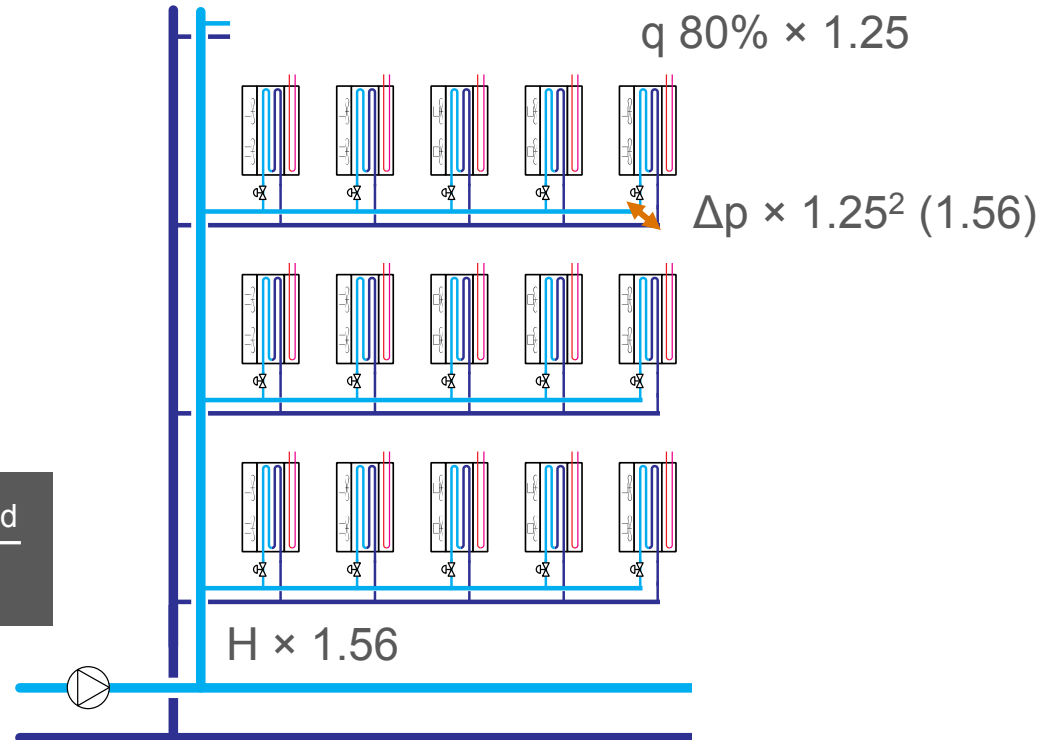

# The Balancing Valve

Engineering  
GREAT Solutions

IMI  
Hydronic  
Engineering

## Idea:

*Adjust the local hydraulic resistances  
(create local  $D_p$ ) so as to obtain  
the required flows*

## The Balancing Valve

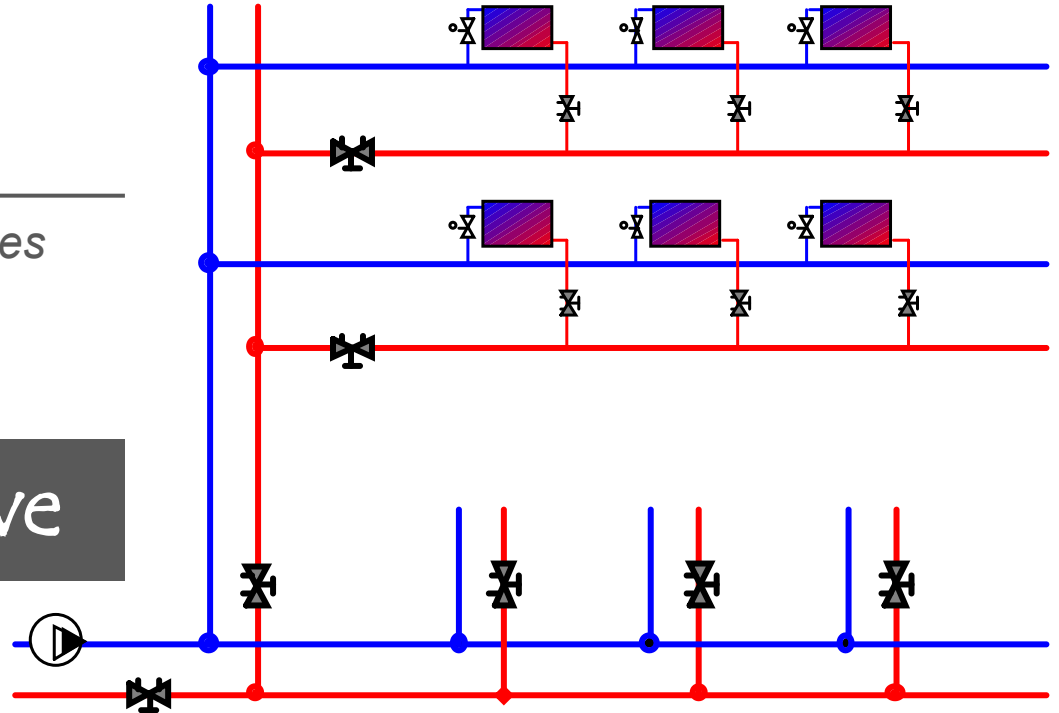

- ▶ **Ability to selectively throttle the flow to a terminal device**
  - ▶ Or branch circuit (several terminal units or sub-branches)
  - ▶ MBVs operate with a fixed, although manually adjustable, resistance
  - ▶ Flow through the MBV depends upon the degree to which it is throttled and the differential pressure placed across it
- ▶ **Ability to measure the resulting flow**
- ▶ **Incorporates the use of “circuit setters”, or devices that utilize a venturi section, or calibrated orifice, to restrict flow (gpm or l/s)**
  - ▶ System is manually balancing at each valve by throttling the valve opening to achieve desired flow
  - ▶ Typically includes a memory stop to hold the setting
- ▶ **Lowest up-front cost**

# Balancing with a Venturi Type Manual Valve

Engineering  
GREAT Solutions

IMI Hydronic  
Engineering

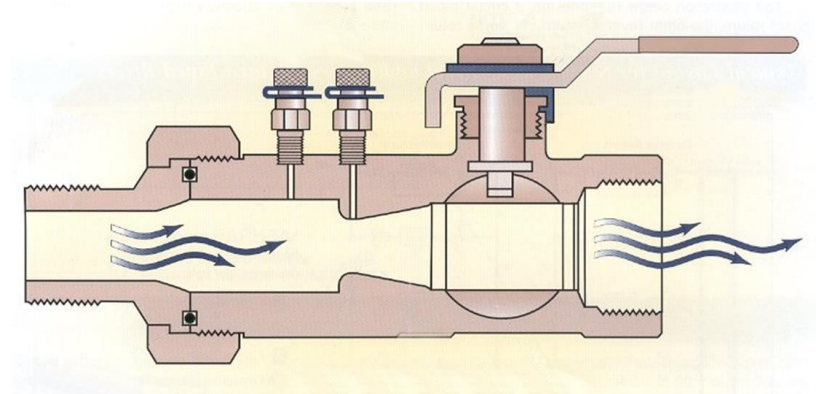
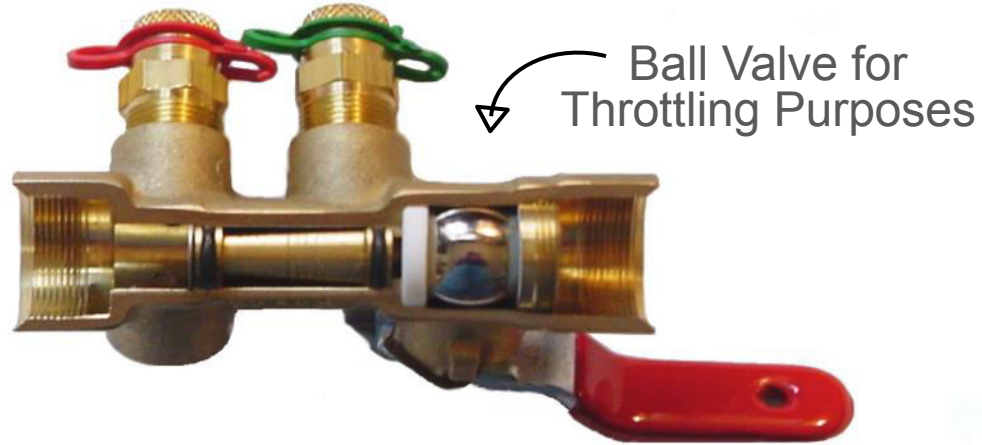

# What is Venturi?

Engineering  
GREAT Solutions

IMI Hydronic  
Engineering

Converting Pressure



Kinetic Energy



Then Back to Pressure

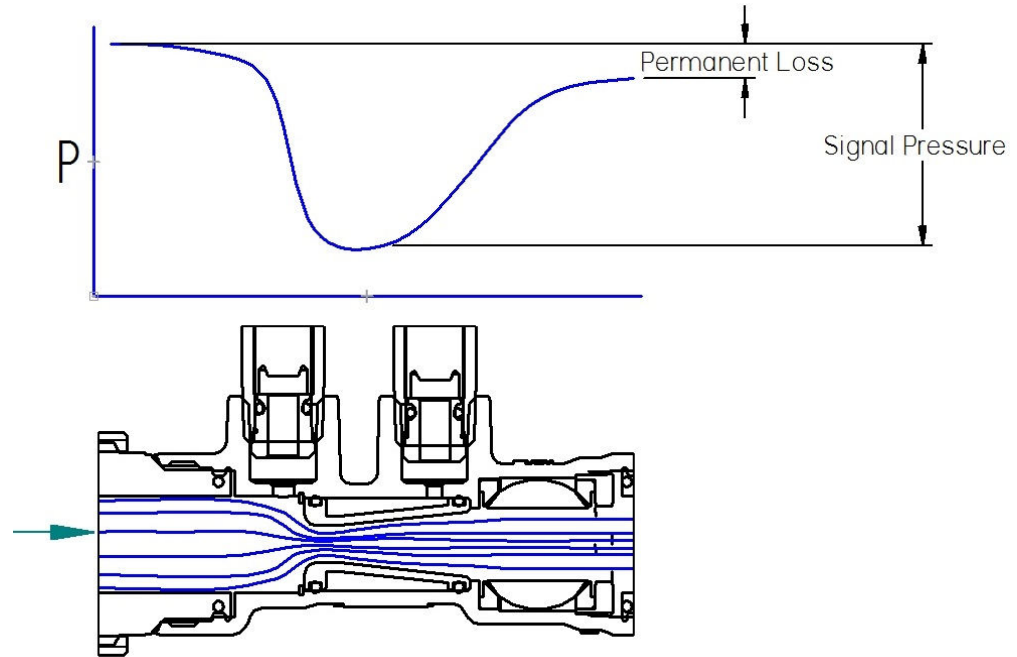

# Why Use a Venturi?

Engineering  
GREAT Solutions



**IMI** Hydronic  
Engineering

- ▶ It conditions the flow
- ▶ The signal pressure on a Venturi is higher than the permanent loss
- ▶ IMI Flow Design's Venturis have been tested to ensure that at any given flow rate the pressure signal is the same regardless where the balancing valve handle is set
- ▶ IMI Flow Design's Venturis are accurate within 3% or better

# Additional Benefits of a Venturi

Engineering  
GREAT Solutions

IMI Hydronic  
Engineering



- ▶ Fixed Cv
- ▶ Flow Measurement
  - ▶ *Integral P/T Ports*
- ▶ Field Adjustable
  - ▶ *With Memory Stop*
- ▶ Low Permanent Pressure Loss
  - ▶ *Almost full recovery*
- ▶ No Wheel Required
  - ▶ *Direct relationship between  $\Delta p$  signal and flow*
- ▶ Least expensive option to achieve balance

# Balancing Made Simple FOMBV

Engineering  
GREAT Solutions

**IMI** Hydronic  
Engineering

Flow Rate (gpm)	1	2	3	4	5	6
0.1	7.3					
0.2	27.1	5.5				
0.3	58.6	12.1				
0.4	101.2	21.2				
0.5	154.7	32.7	6.7			
0.6	218.8	46.7	9.5			
0.65	254.7	54.6	11.1			
0.7	293.3	63.1	12.8			
0.8	378.0	81.9	16.6			
0.9	472.8	103.1	20.9			
0.95	524.0	114.6	23.2			
1.0		126.7	25.6			
1.1		152.6	30.8	5.4		
1.2		180.9	36.5	6.5	5.1	
1.3		211.5	42.6	7.6	6.0	
1.4		244.4	49.1	8.9	6.9	
1.5		279.6	56.2	10.2	7.9	
1.6		317.2	63.6	11.6	9.0	
1.7		357.1	71.6	13.2	10.1	



# VOMBV Balancing and Accuracy

Engineering  
GREAT Solutions

IMI Hydronic  
Engineering

Style	C <sub>v</sub> Values for Sizes listed below <sup>1</sup>					
No. of Turns	½"	¾"	1"	1¼"	1½"	2"
0.50	0.15	0.59	0.70	1.32	2.03	2.97
1.00	0.25	0.88	1.19	2.20	3.83	4.87
1.50	0.36	1.38	2.44	3.60	5.34	8.35
2.00	0.66	2.20	4.20	5.40	7.08	13.60
2.50	1.02	3.24	6.15	8.24	10.20	18.80
3.00	1.60	4.49	8.00	11.00	14.60	24.90
3.50	2.30	5.51	9.28	13.70	18.60	30.70
4.00 <sup>2</sup>	2.92	6.61	10.09	16.50	22.30	38.00

<sup>1</sup> C<sub>v</sub> = GPM at a ΔP of 1 psi/7 kPa) through the valve at any given setting.

1 psi = 2.31 ft. of H<sub>2</sub>O

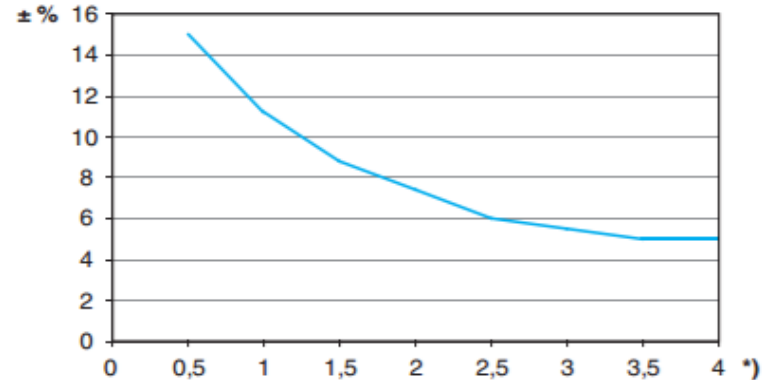
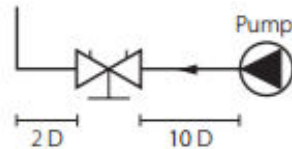
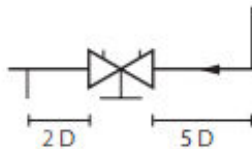

\*) Setting, No. of turns.

- ▶ **Flow Rate Range:**  
0.2 – 9500 USGPM
- ▶ **Pressure Rating:**  
400 psig
- ▶ **Sizes:**  
½" – 16"

- ▶ **Coming Soon:**
  - ▶ *UA eco*
  - ▶ *For DWS*

