

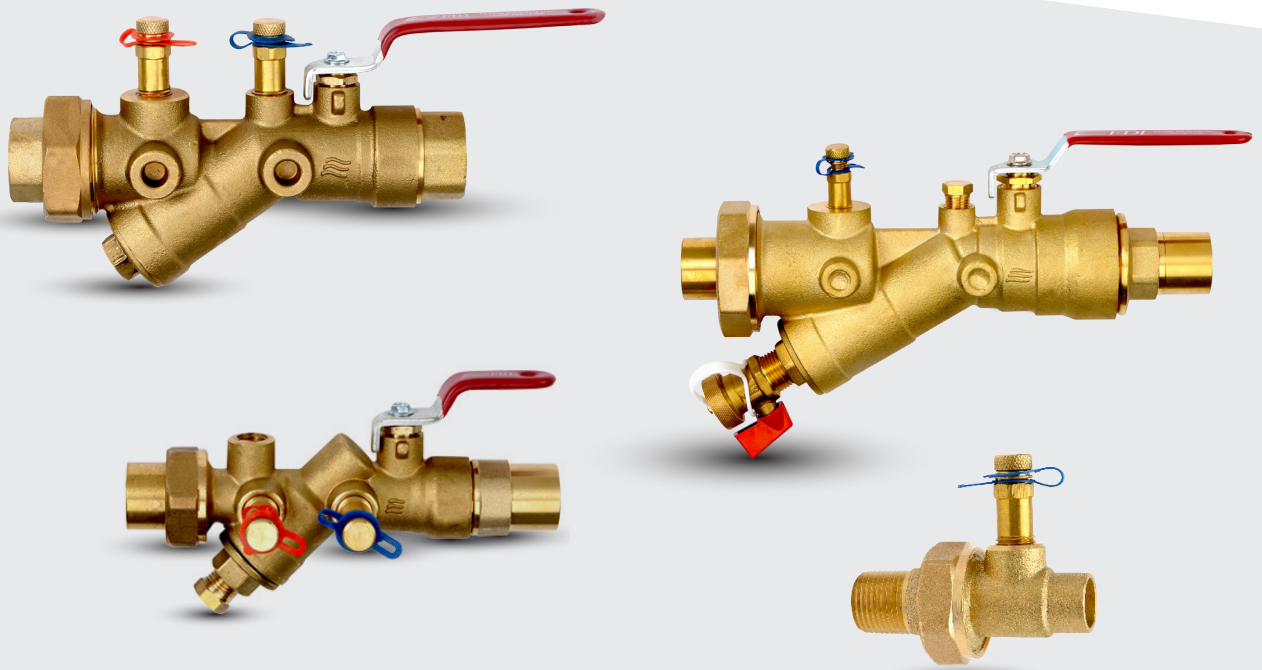

# HU - 1A - 11A



**Automatic Balancing**  
Complete Coil Hook-up Packages

  
*Engineering  
GREAT Solutions*

# HU - 1A - 11A

Everything you need to hook-up a terminal unit except the control valve.

## Key features

### > Supply

- Ball Valve
- 20 Mesh Strainer
- Drain Valve with Hose End & Cap
- Pressure/Temperature Port
- Union Connection to Coil

### > Return

- Union Connection to Coil
- Pressure/Temperature Port
- Manual Air Vent
- Union Connection from Control Valve
- Automatic Flow Regulator
- Dual Pressure/Temperature Ports
- Ball Valve

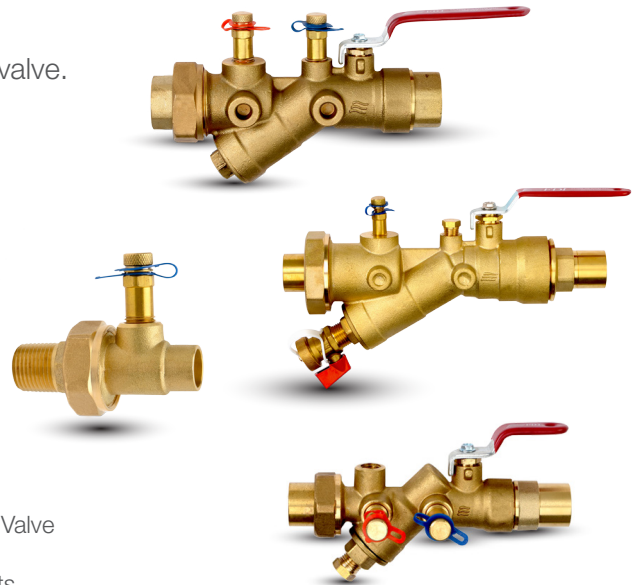

## Technical description

### Application:

Terminal Balancing, strainer measurement

### Functions:

Flow regulator, union and shutt-off

### Dimensions:

1/2" - 2"

### Rating:

400 psig at 250° F (2758 kPa at 120° C)

### Pressure range:

2-32, 5-60, N/A

### Accuracy:

±5%

### Material:

Body: Forged Brass with EPDM O-rings  
Flow cartridge: Series 300 stainless steel  
wear surfaces with stainless steel spring

## HU-1A thru 3A Models

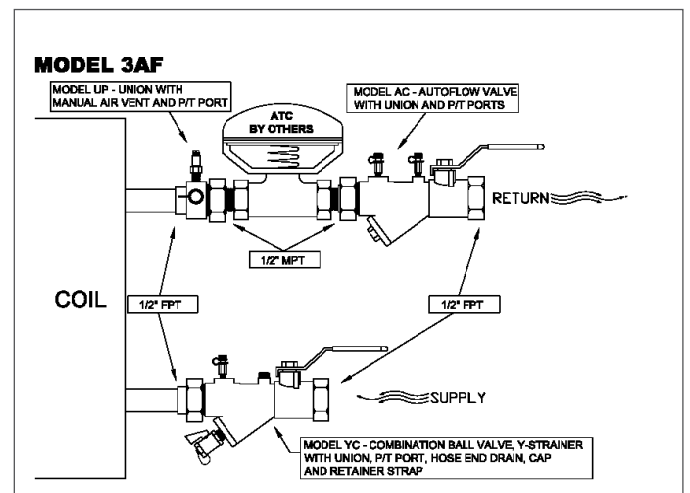
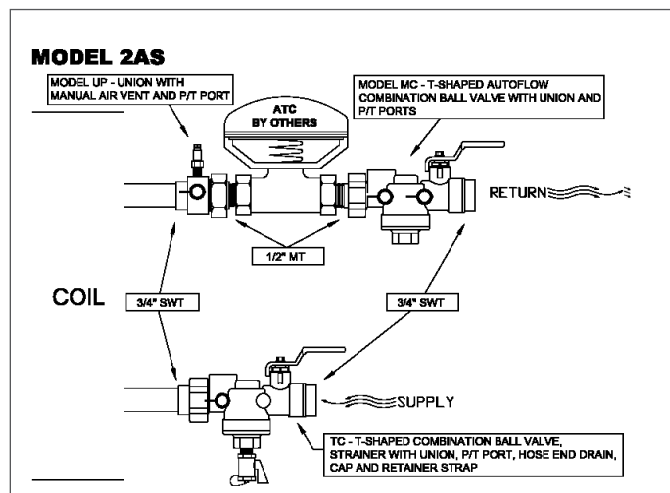
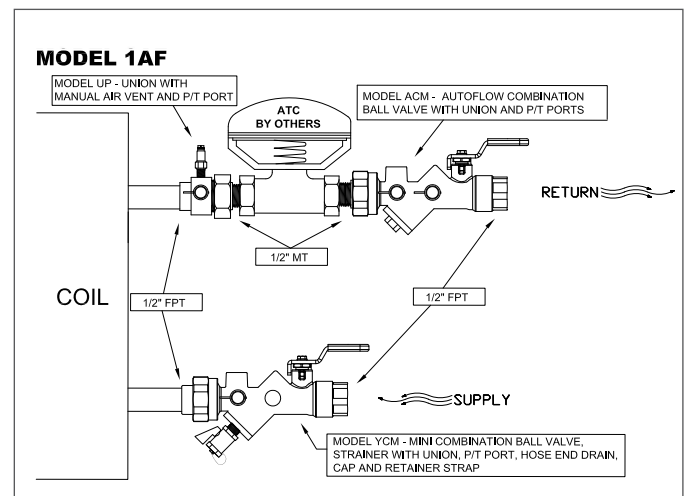
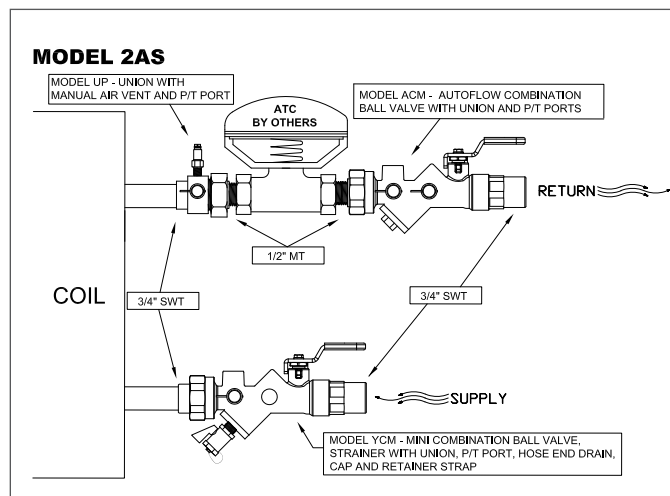
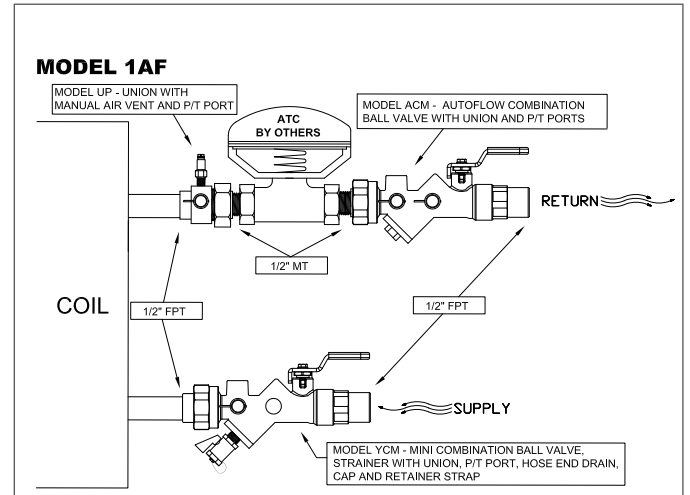
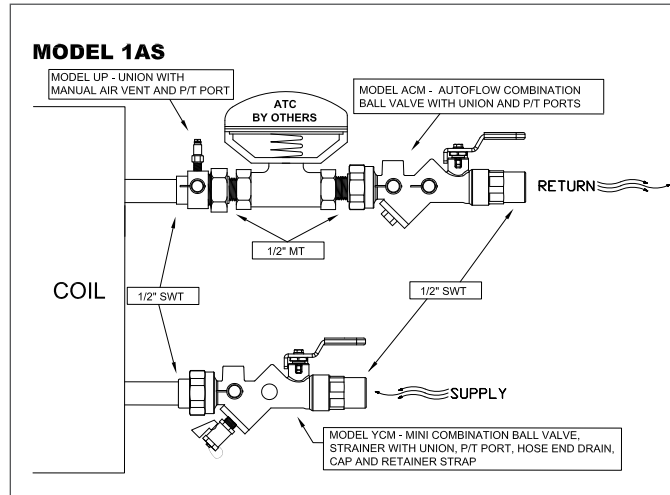

## HU-4A thru 6A Models

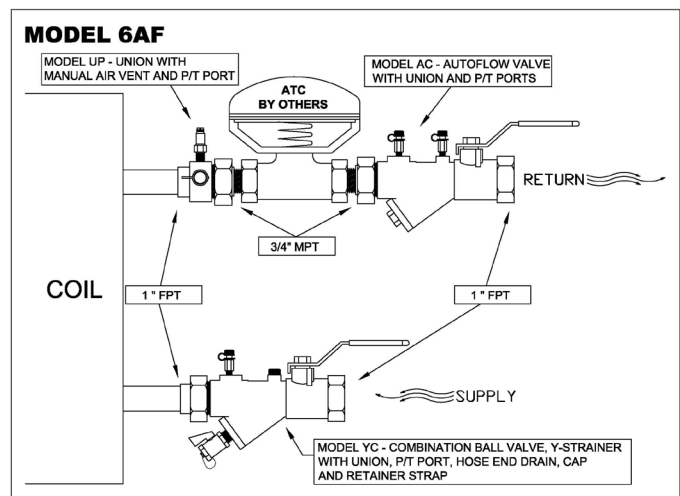
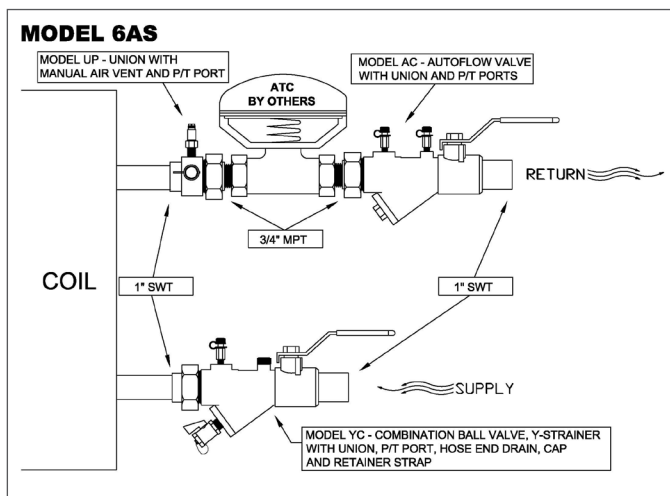
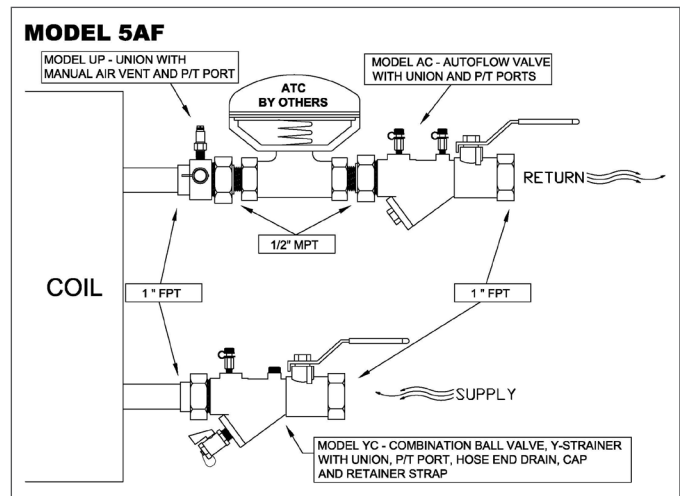
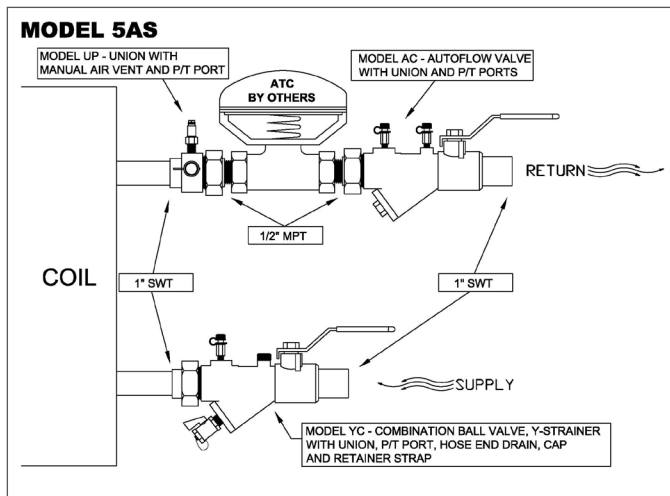
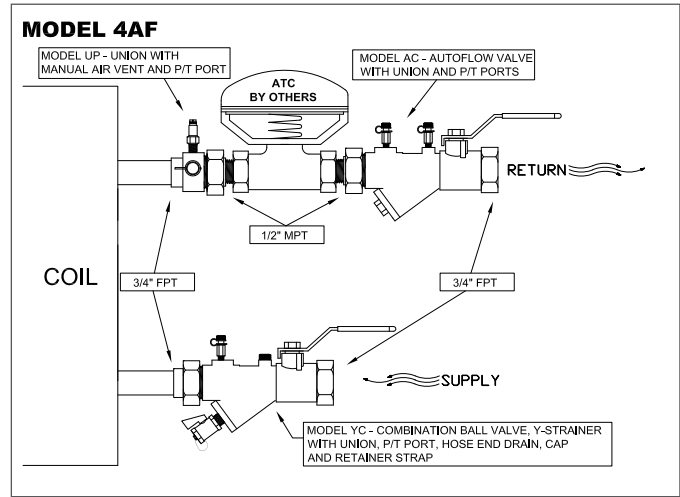
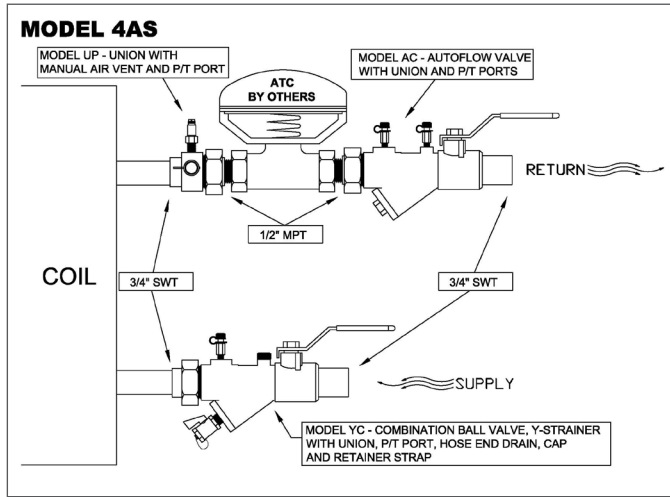

## HU-7A thru 9A Models

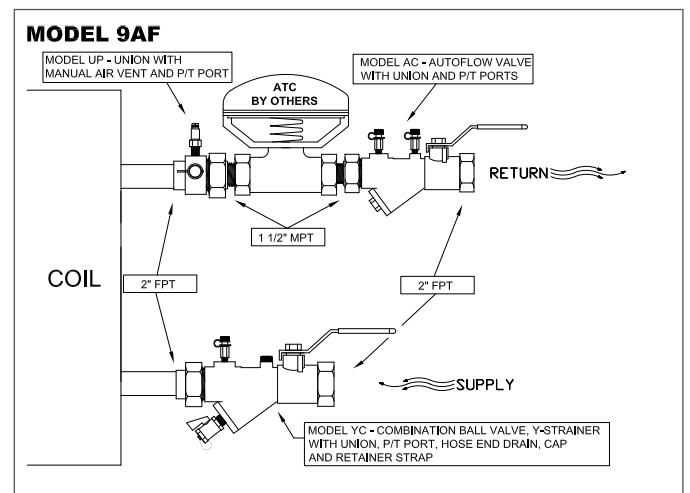
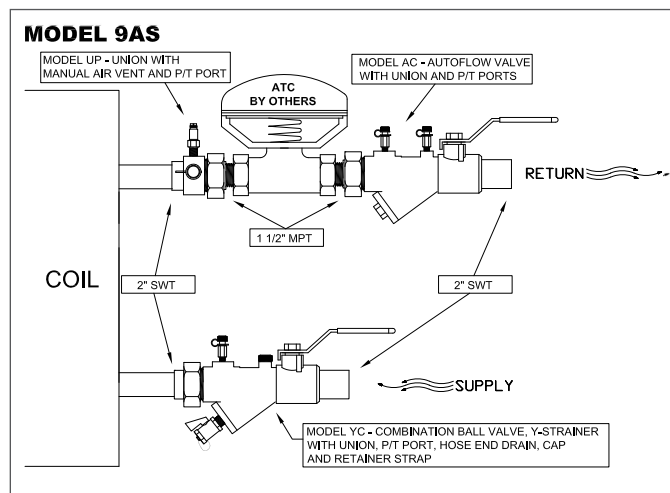
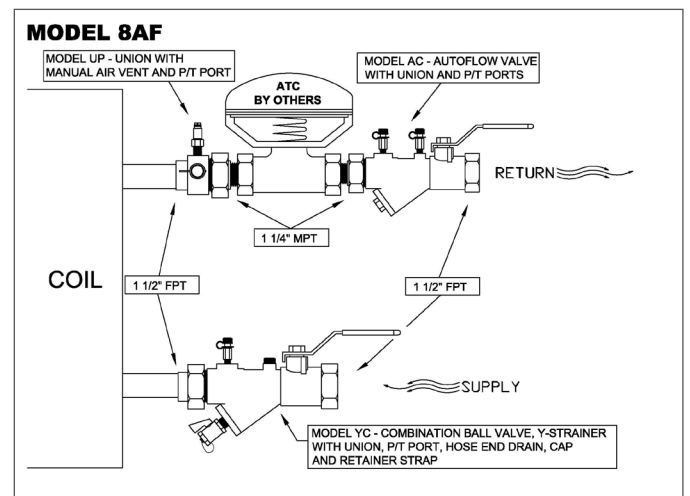
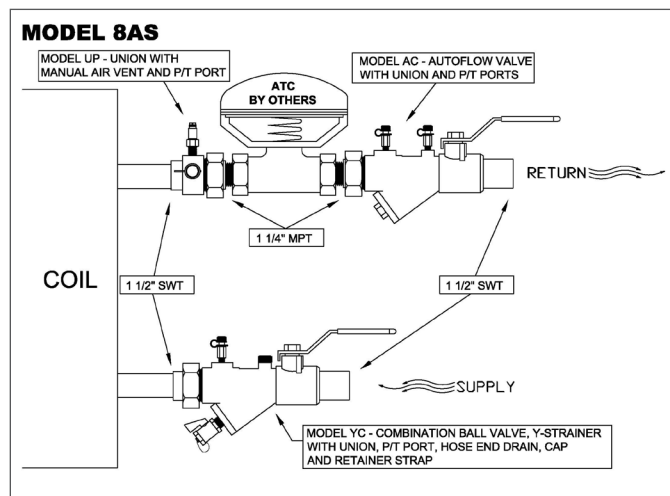
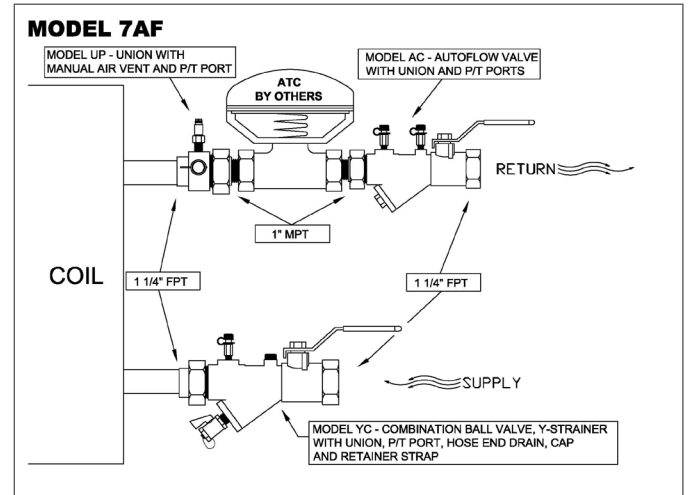
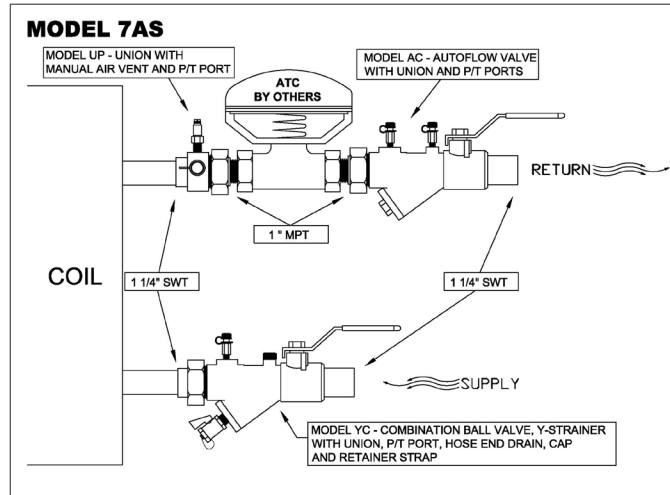

### Notes

Pricing includes "Bag & Tag", HU-AS - Sweat Connection, HU-AF - Female Pipe Thread Connection

## Flow Rates

Available FLOW Rates for 1A - 8A Packages										
gpm (lps)										
1A-2A Flows:	0.50 (.03)	.075 (.05)	1.00 (.06)	1.25 (.08)	1.50 (.09)	1.75 (.11)	2.00 (.13)	2.50 (.16)	3.00 (.18)	
3A-9A Flows:	0.50 (.03)	.075 (.05)	1.00 (.06)	1.25 (.08)	1.50 (.09)	1.75 (.11)	2.00 (.13)	2.25 (.14)	2.50 (.16)	3.00 (.18)
	4.00 (.25)	4.5 (.28)	5.00 (.32)	6.00 (.38)	7.00 (.44)	8.00 (.50)	9.00 (.57)	10.00 (.63)	11.00 (.69)	12.00 (.76)

### Notes

All configurations include an automatic flow regulator with ±5% accuracy over the 2-32 psid control range. For product specific information, please see individual product submittals.

## Program

Complete coil hook-up packages tagged plastic bag and balancing valves are tagged with flow data.\*

Please do not combine complete coil hook-up package purchase orders with standard or QuickShip purchase orders.

No changes are allowed to the product mix, accessories, flows or configuration; standard orders will be processed if changes are required.

Maximum order is 300 hook-ups without factory consultation. Please contact factory for quantities exceeding the maximum.

\*No special tagging, gpm only.

## Model Order Designation

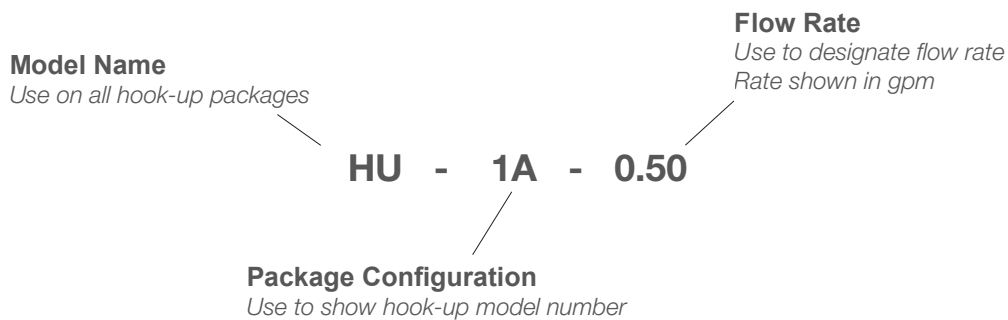

S = female sweat

F = female NPT

M = male NPT

---

**Notes**

