

AA



Accessories

1/4" Brass Automatic Air Vent

*Engineering
GREAT Solutions*

AA

The Model AA025 automatic air vent is designed for continuous air venting in hot and chilled water systems. When used to protect coils, it is best located on the supply side of the coil to prevent air from entering the coil and requiring a service call to vent the air. The unit is best located where pipe velocities are reduced. An ideal location is directly in the body of a Y-strainer. The strainer screen breaks and collects bubbles which are vented by the GR automatic air vent.



Key features

- > **Long Service Life**
The float is the only moving part.
- > **Float**
High temperature resistant polyethylene
- > **Ease of Inspection/Cleaning**

Technical description

Application: Hot and Chilled Water Systems	Connection: 1/4" MPT	Maximum Operating Temperature: 240° F
Functions: For use in applications requiring the steady discharge of air - both initial air and air generated operation	Maximum Operating Pressure: 150 psi	Material: Body: Brass Float: Polypropylene Cap: Nylon

Nominal Dimensions / Applications

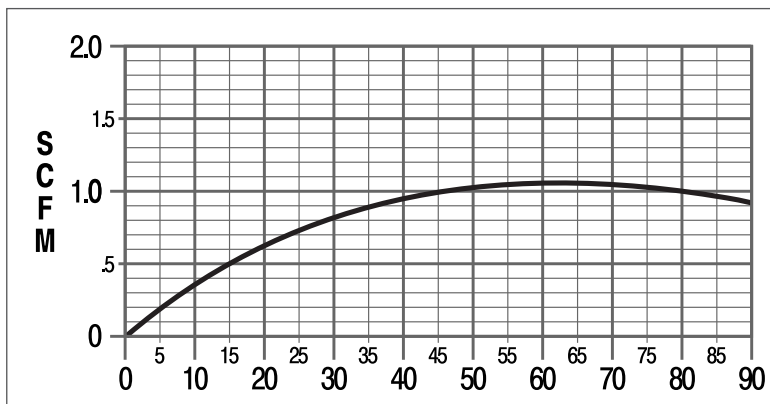
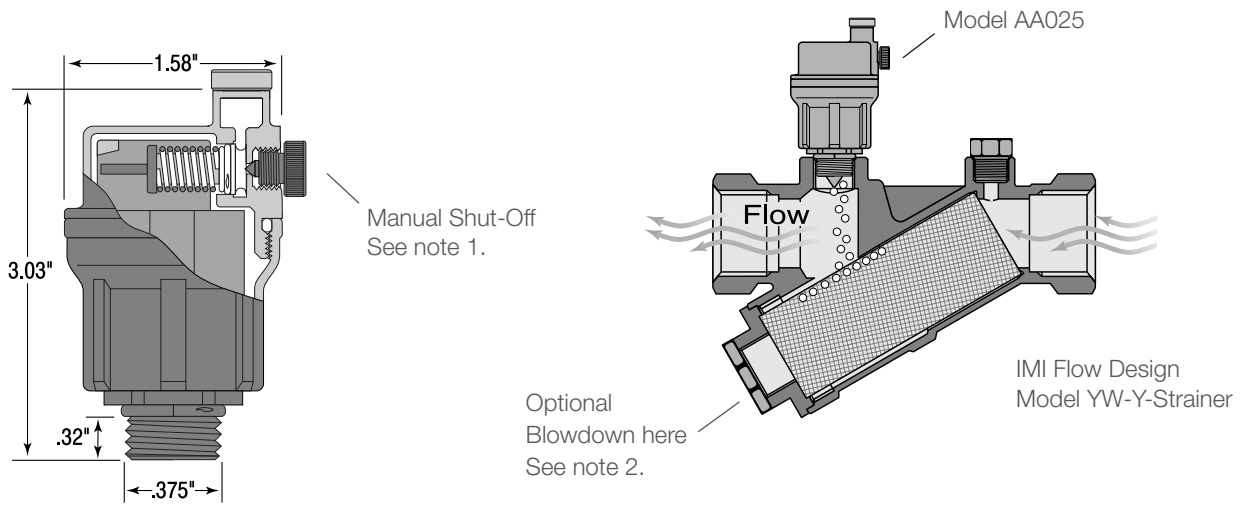

Notes

For continuous air venting cap should remain open one full turn.
 The Y-strainer should always be equipped with a blowdown valve.
 Dimensions not to be used for construction unless prints certified
 by factory.

